



DRYING

STACK DRYERS ADVANCE SR-2-11/14/18 TP2



CHARACTERISTICS

TP2

- User friendly and totally programmable 7" TP2.
- USB Connection. Online platform free of charge for programming, telemetry, data analysis...thanks to the IoT.
- Videos on display (ads, instructions, etc).
- 37 languages.

OUTSTANDING FEATURES

- Reversing drum action as standard.
- Stainless steel drum as standard.
- Frequency inverter as standard.

EFFICIENCY

- MIXED FLOW - mixed axial-radial airflow.
- Big fluff filter.

VERSATILITY

- Make to order - customisation.
- WET CLEANING.
- OPL > Multivending - Standard OPL model easily trasformable to coin laundry uses.

CONNECTIVITY

- Standard IoT FagorKconnect.
- Management of laundries: OPL and COIN.
- Remote payment (coin laundry).

ERGONOMICS

- Drawer as fluff filter, made of stainless steel.
- Biggest door diameters.

MAINTENANCE

- Hinged panel: easy and ergonomic access.
- **Technical menu: statistics for technicians and maintenance with external console (with console option).**

OTHERS

- Grey skinplate outer casing, stainless steel look.
- SOFT TOUCH - new drum with stamped holes.
- COOL DOWN - anti-wrinkle at the end of the cycle.
- Heating options: electric, gas.
- CE approved.

OPTIONS

- iDRY - Intelligent humidity control. Temperature probe at drum inlet.
- Double door glass.
- FK - Integrated Fire Extinguishing System.
- Tropicalized model.
- Opposite door opening.
- Dosing-spraying.
- Back panel external air + filter.
- Fluff filter with grid 0,3 mm (standard in STACK is 0,6 mm)
- Stainless steel front and side panles.
- Stainless steel frontal panel.
- Maritime wooden packing.
- Ship voltage for electric models: 440V III 50/60 Hz No neutral.
- Other voltages available.

TECHNICAL DATA	UNIT.	SR-2-11 TP2	SR-2-14 TP2	SR-2-18 TP2			
CAPACITY							
Capacity 1/18	Kg	24	30	36			
Capacity 1/20	Kg	22	28	34			
Hourly Output (electr. // gas)	Kg/h	31,6 // 30,6	34,4 // 33,8	36,2 // 36			
Evaporation capacity (electr. // gas)	l/h	15,8 // 15,3	17,2 // 16,9	18,1 // 18			
DRUM							
Ø Drum	mm	750	750	750			
Ø Door	mm	574	574	574			
Door center height	mm	547 / 1.522	547 / 1.522	547 / 1.522			
Load hole bottom height	mm	260 / 1.235	260 / 1.235	260 / 1.235			
Drum length	mm	475	610	746			
Drum volume	l	210	269	330			
POWER							
Drum motor power	Kw	0,37 x 2	0,37 x 2	0,37 x 2			
Fan motor power	Kw	0,25 x 2	0,25 x 2	0,25 x 2			
Electric heating power	Kw	12 x 2	12 x 2	12 x 2			
Total electric power (elec.model)	Kw	25,34	25,34	25,34			
Gas heating power	Kw	12x2	12x2	12x2			
Instant propane gas consumption (G31)	Kg/h	1,03 x 2	1,03 x 2	1,03 x 2			
Instant natural gas consumption (G20)	m3/h	1,27 x 2	1,27 x 2	1,27 x 2			
Total electric power (gas model)	Kw	1,34	1,34	1,34			
CONNECTIONS		ELECTRIC.	GAS	ELECTRIC.	GAS	ELECTRIC.	GAS
Tension 230V - I + N + T	N° x mm2 / A	-	3 x 1,5 / 20A	-	3 x 1,5 / 20A		3 x 1,5 / 20A
Tension 230V - III + T	N° x mm2 / A	4 x 25 / 80A	3 x 1,5 / 20A	4 x 25 / 80A	3 x 1,5 / 20A	4 x 25 / 80A	3 x 1,5 / 20A
Tension 400V - III + N + T	N° x mm2 / A	5 x 10 / 40A	3 x 1,5 / 20A	5 x 10 / 40A	3 x 1,5 / 20A	5 x 10 / 40A	3 x 1,5 / 20A
Ø Gas inlet	BSP	1/2"		1/2"		1/2"	
DIMENSIONS / PACKING DIMENSIONS							
Net width / Gross width	mm	785 / 865		785 / 865		785 / 865	
Net Depth / Gross Depth	mm	972 / 1.055		1.106 / 1.189		1.242 / 1.325	
Net Height / Gross Height	mm	1.980 / 2.126		1.980 / 2.126		1.980 / 2.126	
Net weight / Gross weight	Kg	260 / 268		275 / 293		290 / 317	
OTHERS							
Max airflow	m3/h	500 x 2		500 x 2		500 x 2	
Ø Fume exhaust	mm	200		200		200	
Sound level	dB	64		64		64	

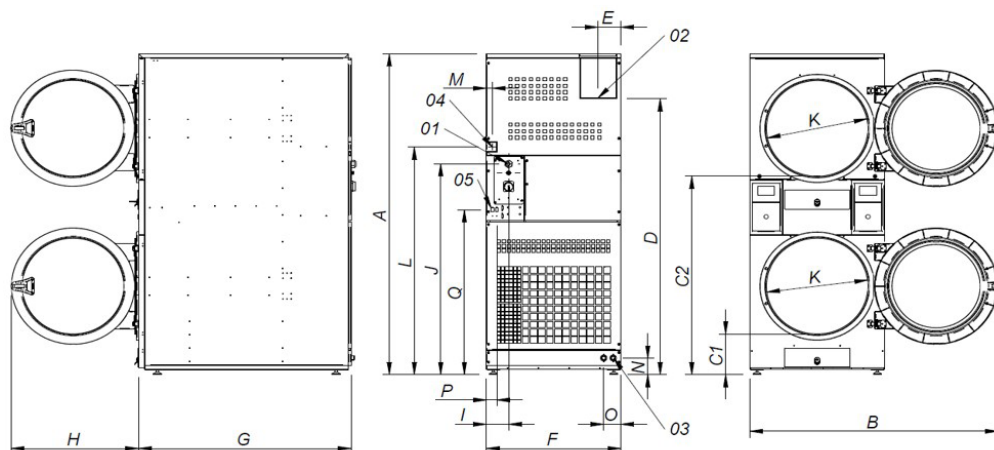

- 01 POWER SUPPLY
- 02 FUMES OUTPUT Ø200
- 03 2 SPRINKLER VALVES 3/4"
- 04 GAS INLET 1/2"
- 05 ETHERNET CONNECTION

	A	B	C1	C2	D	E	F	G	H	I	J	K	L	M	N	O	P	Q
SR-2-11 TP2	1980	1447	259	1234	1680	135	785	972	735	130	1275	575	1406	35	103	100	60	1018
SR-2-14 TP2	1980	1447	259	1234	1680	135	785	1106	735	130	1275	575	1406	35	103	100	60	1018
SR-2-18 TP2	1980	1447	259	1234	1680	135	785	1242	735	130	1275	575	1406	35	103	100	60	1018

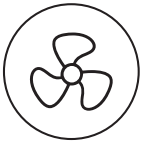

DRYING

STACK DRYERS POWERED SR/SC-2-18 TP2/M POWERED

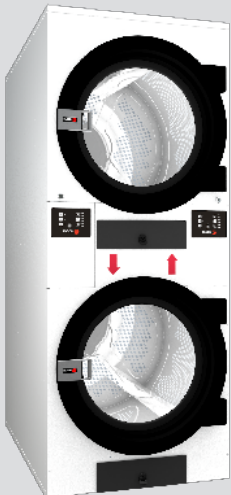

CHARACTERISTICS

SR-2-18 TP2 POWERED

- User friendly and totally programmable 7" TP2
- Reversing drum action as standard
- Stainless steel drum as standard
- New POWERED gas heated model: more power to achieve more productivity.
- OPL > Multivending
- IoT FagorKconnect

SR-2-18 M POWERED

- New M programmer: push buttons to control temperature and time
- Reversing drum action as standard
- Stainless steel drum as standard
- New POWERED gas heated model: more power to achieve more productivity.
- OPL > Multivending

SC-2-18 M POWERED

- New M programmer: push buttons to control temperature and time
- Reversing drum action as standard
- Galvanized drum as standard
- New TURBO gas heated model: more power to achieve more productivity.
- OPL > Multivending

OPTIONS

SR-2-18 TP2 POWERED

- iDRY - Intelligent humidity control.

SR-2-18 M POWERED

- Screen in M programmer

SC-2-18 M POWERED

- Screen in M programmer

TECHNICAL DATA	UNIT	SR-2-18 TP2 POWERED	SR-2-18 M POWERED	SC-2-18 M POWERED			
CAPACITY							
Capacity 1/18	Kg	37	37	37			
Capacity 1/20	Kg	34	34	34			
Hourly Output (gas)*	Kg/h	35,3	35,3	35,3			
Evaporation capacity (gas)*	l/h	70,7	70,7	70,7			
DRUM							
Ø Drum	mm	750	750	750			
Ø Door	mm	574	574	574			
Door center height	mm	547 / 1.522	547 / 1.522	547/1522			
Load hole bottom height	mm	260 / 1.235	260 / 1.235	260/1235			
Drum length	mm	746	746	746			
Drum volume	l	330	330	330			
POWER							
Drum motor power	Kw	0,37x2	0,37x2	0,37x2			
Fan motor power	Kw	0,55x2	0,55x2	0,55x2			
Electric heating power	Kw	-	-	-			
Total electric power (elec.model)	Kw	-	-	-			
Gas heating power	Kw	24x2	24x2	24x2			
Total electric power (gas model)	Kw	1,94	1,94	1,94			
CONNECTIONS		ELECTRICAL	GAS	ELECTRICAL	GAS	ELECTRICAL	GAS
Tension 230V - I + N + T	N° x mm2 / A	-	3x1,5 / 20A	-	3x1,5 / 20A	-	3x1,5 / 20A
Tension 230V - III + T	N° x mm2 / A	4x25 / 80A	3x1,5 / 20A	4x25 / 80A	3x1,5 / 20A	4x25 / 80A	3x1,5 / 20A
Tension 400V - III + N + T	N° x mm2 / A	5x10 / 40	3x1,5 / 20A	5x10 / 40	3x1,5 / 20A	5x10 / 40	3x1,5 / 20A
Ø Gas inlet	BSP	1/2"		1/2"		1/2"	
DIMENSIONS / PACKING DIMENSIONS							
Net width / Gross width	mm	785 / 865		785 / 865		785 / 865	
Net Depth / Gross Depth	mm	1443 / 1457		1443 / 1457		1443 / 1457	
Net Height / Gross Height	mm	1980 / 2126		1980 / 2126		1980 / 2126	
Net weight / Gross weight	Kg	320 / 349		320 / 349		320 / 349	
OTHERS							
Max airflow	m3/h	750x2		750x2		750 x 2	
Ø Fume exhaust	mm	200x2		200x2		200x2	
Sound level	dB	64		64		64	

* It may vary depending on the type of heating, filter cleanliness or extraction type

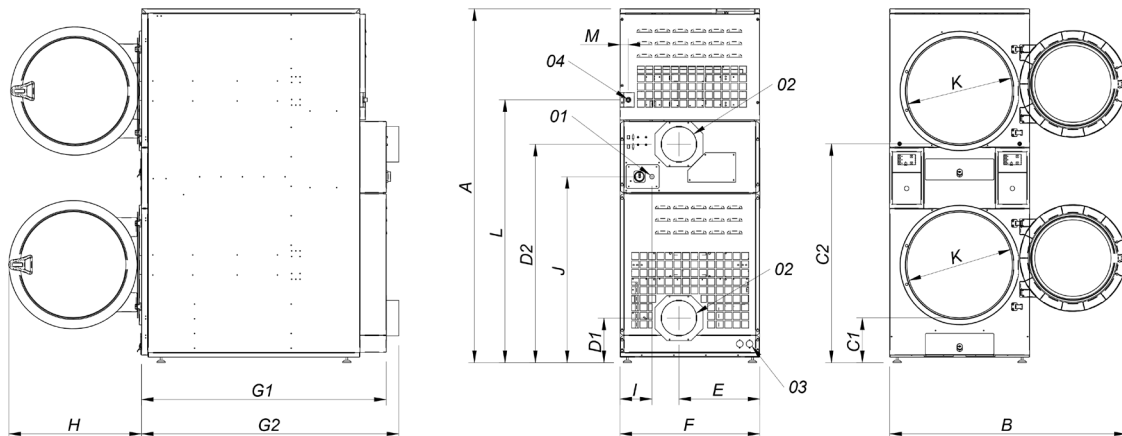

- 01 ELECTRIC CONNECTION
- 02 2 FUMES OUTPUT Ø200
- 03 2 SPRINKLER VALVES 3/4"
- 04 GAS INLET 1/2"
- 05 ETHERNET CONNECTION (ONLY TOUCH CONTROL)

	A	B	C1	C2	D1	D2	E	F	G1	G2	H	I	J	K	L	M
SR-2-18 TP2 POWERED	1980	1447	259	1234	250	1223	454	785	1374	1443	735	180	1017	575	1472	45
SR-2-18 M POWERED	1980	1447	259	1234	250	1223	454	785	1374	1443	735	180	1017	575	1472	45
SC-2-18 M POWERED	1980	1447	259	1234	250	1223	454	785	1374	1443	735	180	1017	575	1472	45



DRYING

STACK DRYERS ADVANCE SR-2-22 TP2



CHARACTERISTICS

TP2

- User friendly and totally programmable 7" TP2.
- USB Connection. Online platform free of charge for programming, telemetry, data analysis...thanks to the IoT.
- Videos on display. (ads, instructions, etc).
- 37 languages.

OUTSTANDING FEATURES

- Reversing drum action as standard.
- Stainless steel drum as standard.
- Frequency inverter as standard.

EFFICIENCY

- MIXED FLOW - mixed axial-radial airflow.
- Big fluff filter.

VERSATILITY

- Make to order - customisation.
- WET CLEANING.
- OPL > Multivending - Standard OPL model easily trasformable to coin laundry uses.

CONNECTIVITY

- Standard IoT FagorKconnect.
- Managemant of laundries: OPL and COIN.
- Remote payment (coin laundry)

ERGONOMICS

- Drawer as fluff filter, made of stainless steel.
- Biggest door diameters.

MAINTENANCE

- Hinged panel: easy and ergonomic access.
- **Technical menu: statistics for technicians and maintenance with external console (with console option).**

OTHERS

- Grey skinplate outer casing, stainless steel look.
- SOFT TOUCH - new drum with stamped holes.
- COOL DOWN - anti-wrinkle at the end of the cycle.
- Heating options: electric, gas.
- CE approved.

OPTIONS

- iDRY - Intelligent humidity control. Temperature probe at drum inlet.
- Double door glass.
- FK - Integrated Fire Extinguishing System.
- Tropicalized model.
- Opposite door opening.
- Dosing-spraying.
- Back panel external air + filter.
- Fluff filter with grid 0,3 mm (standard in STACK is 0,6 mm).
- Stainless steel front and side panles.
- Stainless steel frontal panel.
- Maritime wooden packing.
- Ship voltage for electric models: 440V III 50/60 Hz No neutral.
- Other voltages available.

TECHNICAL DATA	UNIT.	SR-2-22 TP2
CAPACITY		
Capacity 1/18	Kg	48
Capacity 1/20	Kg	44
Hourly Output (gas)	Kg/h	88
Evaporation capacity (gas)	l/h	44
DRUM		
Ø Drum	mm	835
Ø Door	mm	574
Door center height	mm	547 / 1.618
Load hole bottom height	mm	272 / 1.322
Drum length	mm	800
Drum volume	l	438
POWER		
Drum motor power	Kw	0,37 x 2
Fan motor power	Kw	0,55 x 2
Electric heating power	Kw	-
Total electric power (elec.model)	Kw	-
Gas heating power	Kw	30,4 x 2
Instant propane gas consumption (G31)	Kg/h	1,03 x 2
Instant natural gas consumption (G20)	m3/h	1,27 x 2
Total electric power (gas model)	Kw	1,94
CONNECTIONS		GAS
Tension 230V - I + N + T	Nº x mm2 / A	3 x 1,5 / 20A
Tension 230V - III + T	Nº x mm2 / A	-
Tension 400V - III + N + T	Nº x mm2 / A	-
Ø Gas inlet	BSP	3/4"
DIMENSIONS / PACKING DIMENSIONS		
Net width / Gross width	mm	870 / 950
Net Depth / Gross Depth	mm	1.328 / 1.411
Net Height / Gross Height	mm	2.117 / 2.250
Net weight / Gross weight	Kg	PENDIENTE
OTHERS		
Max airflow	m3/h	900 x 2
Ø Fume exhaust	mm	250
Sound level	dB	69

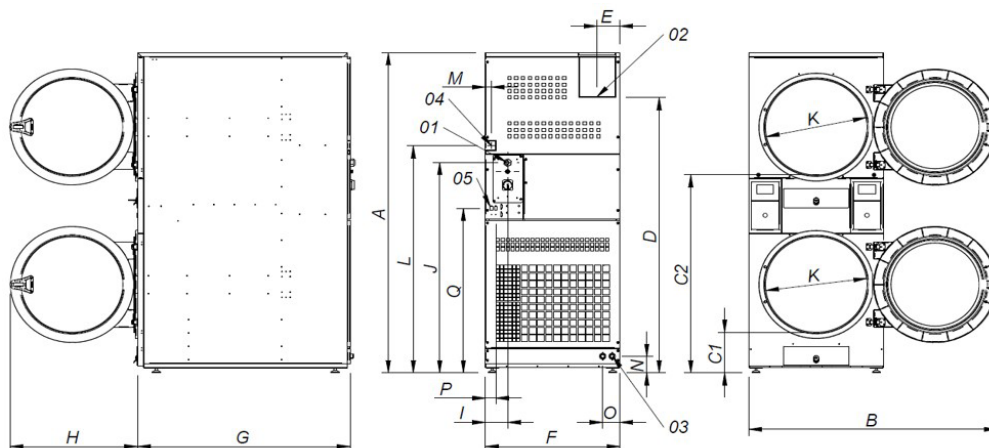

- 01 POWER SUPPLY
- 02 FUMES OUTPUT Ø200
- 03 2 SPRINKLER VALVES 3/4"
- 04 GAS INLET 1/2"
- 05 ETHERNET CONNECTION

	A	B	C1	C2	D	E	F	G	H	I	J	K	L	M	N	O	P	Q
SR-2-22 TP2	2118	1490	286	1330	1940	149	870	1312	735	73	320	575	250	70	100	145	45	1416